

# Renewable Energy Generation from Repetitive Human Activity: Proposal for a Door-Opening Based Electric Generator

Matthew Bonanni, Peter Groen, Brian Liang, Owen Porth, Spencer Pozder  
College of Engineering  
Northeastern University

The current global climate change crisis necessitates increased research in the field of renewable energy. Much of the energy that humans exert through their daily activity is wasted, and could potentially be a useful source of renewable power. Around the world, multitudes of doors are each opened as many as thousands of times per day, releasing appreciable amounts of energy. This paper proposes a design for a Door Motion Generator, a device capable of generating electricity through the motion of opening said doors. Such a device could harvest a vastly fruitful source of energy that is entirely wasted in the current world, with little economic or personal impact on the daily lives of the populace. The Door Motion Generator is compatible with almost all existing doors and produces no harmful waste. If implemented properly and wholly, this generator and other non-intrusive “daily life” generators could contribute meaningfully to the global energy supply.

*Corresponding Author: Matthew Bonanni, bonanni.m@husky.neu.edu*

## Introduction

Over the past three decades, many developed nations have conducted comprehensive research in previously untapped sources of renewable energy. Huge advancements in photovoltaic, wind, geothermal, wave, and biofuel technologies have revolutionized a world once powered by fossil fuels. Novel developments in these fields have come to supply nearly a quarter of the power demanded by the world’s citizens (“Renewable Energy,” n.d.); yet, one burgeoning reservoir of clean, renewable energy has been largely ignored. Humans exert energy performing tasks every day — from the force applied in every footstep to the body heat energy naturally generated every second (Anthony, 2012). Instead of allowing all of this energy to dissipate into the surroundings, laboratories have begun to design products and even entire facilities which harvest the forces of daily interactions between people and their urban environment. Previously, any electricity generated from daily human motions was too insignificant to be of any use. Now, inventions like “Power Felt” (Kiger, 2012) which produces small amounts of electricity from body heat, miniature shoe generators, or even energy-capturing floors are showing the potential of human power. Employing these devices, people could one day generate their own power simply from going about their daily lives.

One such device which could generate electricity reliably and safely from simple human movement is a Door Motion Generator. The Door Motion Generator — hereafter referred to as DMG — converts the kinetic

energy of a door’s movement into electrical energy, without significantly increasing the effort required to open the door. With few recurring costs, electricity produced in this manner could power lights on location, operate automatic door openers for handicapped users, or accumulate in batteries for later use. Such a device would be simple to implement, as its design is compatible with existing doors. It would not interfere with standard operation of the door, which is important in emergency situations. Finally, it is designed to be both durable and repairable. If all of the energy from opening doors were to be collected, though the individual amounts are small, the collective accumulated energy would be significant.

This project not only serves to demonstrate the potential of repetitive human motion but also to highlight the opportunity for furthering engineering education through team-based design initiatives—a main mission of the ASEE conference. (“The Organization: American Society for Engineering Education,” 2016)

## Method

### Design Considerations

Once the decision had been made to develop a Door Motion Generator, a design matrix was used to evaluate the desired characteristics of the final design. Given the nature of the device and its use in busy areas, safety had to be the top priority. The DMG could also not interfere with the normal functionality of the door at any time, or increase the force required to open the door to levels difficult or unsafe for any user.

After safety, the efficiency with which the Door Motion Generator produced electricity was the most important design goal. Most of the team's brainstorming efforts were devoted to mechanisms which could increase the amount of electricity produced with each door opening. One promising idea was to keep the generator axle spinning for a short time after a door opening. This could be achieved by adding a flywheel or by making the outer ratchet out of a dense material such that it would obtain this function. Also considered was the insertion of a planetary gearbox to increase the number of generator axle rotations per door opening. Both parts were omitted from the prototype to lower build cost, but could be included in subsequent generations of the DMG. More important than optimizing efficiency, however, was a clutch mechanism. This was added to prevent polarity reversal caused by the generator spinning in opposite directions with the opening and closing of the door.

Because of the nature of the DMG, durability and ease of repair were deemed secondary design goals. The DMG is designed to be mounted in many different buildings, therefore it should be easy to maintain, without special training. To try and achieve high durability, the number of moving parts in the original sketches and CAD assemblies was minimized to reduce risk of failure. To ensure ease of repair in the case of a breakdown, no component of the device was made to be glued, welded, or otherwise permanently attached. This ensures that any broken part can easily be removed and replaced.

### Door Usage Estimation

To motivate the study, a scientific test was conducted in order to more accurately measure how many times one door is opened in a given day. In order to measure this, the group developed a Door Open Counter. The device consists of an ATmega168 microcontroller, which is connected to a push button switch, an LED, and an LCD. A 3D printed arm is attached to the door, and as the door closes, the arm depresses the button, and turns on the LED indicator. The microcontroller, programmed in C++, counts the number of times that this occurs, and displays the number on the LCD.

After obtaining approval from the College of Engineering, the device was installed and began counting.<sup>1</sup> [Table 1] The selected door is located at the heavily trafficked main entrance of Snell Engineering, which consists of two sets of double doors. The counter sits on the frame of the right inner door and is not visible to those entering the building. It was important to consider that only complete openings and closings are recorded; if the door is held open as subsequent people

<sup>1</sup> Weeks are non-consecutive. Openings only measured on weekdays.

enter, then the movement that occurs between complete closings is not recorded.

<b>Daily Average</b>	1,587.30
<b>2-Week Total</b>	15,873
<b>Week 1</b>	9,215
<b>Week 2</b>	6,658

**Table 1: Door Open Data**

After some time, the average count was determined to be 1,587.3 full closings per day, a number used to further extrapolate the daily power output of the Door Motion Generator. While no single observed number could serve as an accurate estimate for every door on campus, a general benchmark can be made for frequently used doors. Knowing this data will give insight to the timeline for the generator's return on investment. A limited amount of data has been collected at this point, so the team will continue collecting data to develop a more accurate model of the door's opening statistics.

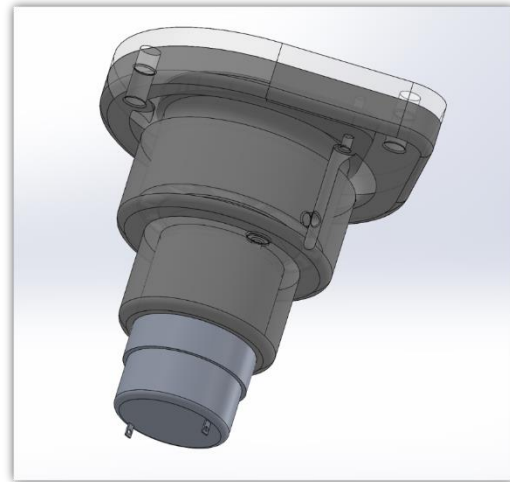

**Figure 1: Complete Assembly**

### Final Design<sup>2</sup>

The initial design for this project was based on the concept of a lawnmower starter. By attaching the end of the ripcord to the door and coiling the other end around a pulley, the opening motion spins the axle of the generator to produce electrical current. This initial design was revised many times as new research and ideas were produced. One of the first additions was the centrifugal clutch mechanism, which was implemented in order to keep the generator axle turning in one direction and prevent polarity reversal. A second addition was the recoil spring which, like a lawnmower starter, causes the ripcord to retract. This addition was crucial in ensuring

<sup>2</sup> SolidWorks drawings available at: <http://1drv.ms/1NFkg3A>



towards even more improvements in future iterations of the device.

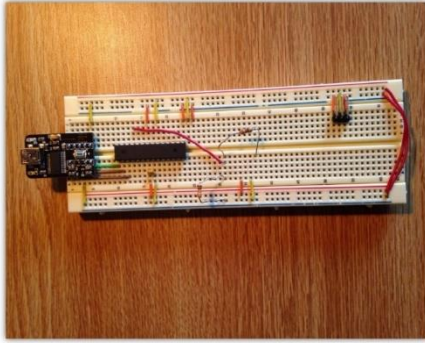

**Figure 4: Voltage Reader**

### Voltage Data Collection

Once the device was finished, it was necessary to measure the amount of energy generated with each pull. In order to accomplish this, the team developed a circuit board capable of measuring the voltage between two probes and sending that data via a serial connection, from which it could be interpreted by a computer using MATLAB. [Figure 4] The data could then be viewed and plotted in real time, as well as stored for later use. This information, in conjunction with the door opening data, provides the necessary information to determine the amount of time required to offset the cost of the device.

The data collected from both the door counter [Table 1] and voltmeter [Figure 4] [Figure 5] is combined to determine the time required for the DMG to produce a given amount of electricity. The door counter gives us an estimated number of openings — each producing a certain amount of electricity — in a specific amount of time, and the voltmeter gives the amount of electricity produced per pull.

### Results

As shown in Table 1, the average amount of door openings that occur, per door, per day, is upwards of 1500. Thus, we can expect any similar door to be opened more than 1500 times per day, producing a predictable amount of electricity per day when connected to the DMG.

The voltmeter measurements are used to calculate the amount of electric charge (in milliamp seconds) produced by one activation of the DMG. Specifically, the voltmeter measures the electric potential in the circuit (voltage) over time, which can then be used to calculate the current and power generated by the device.

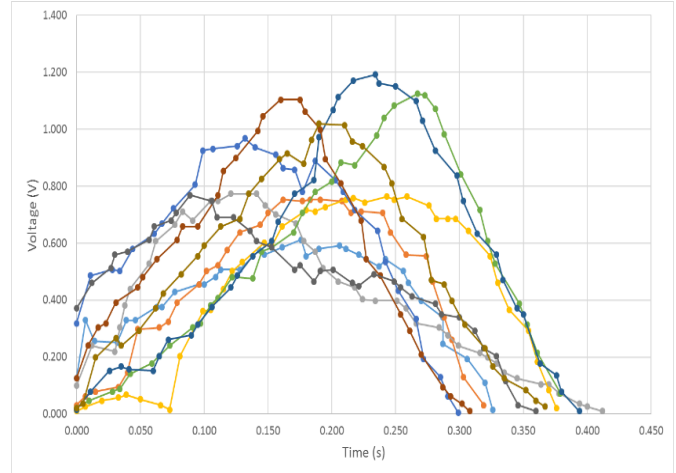

**Figure 5: Voltage vs Time, 10 Samples**

	Total Area	Time (s)	Average Voltage (V)
<b>Pull 1</b>	0.139	0.326	0.427
<b>Pull 2</b>	0.151	0.319	0.474
<b>Pull 3</b>	0.165	0.412	0.401
<b>Pull 4</b>	0.172	0.376	0.457
<b>Pull 5</b>	0.195	0.299	0.653
<b>Pull 6</b>	0.209	0.379	0.552
<b>Pull 7</b>	0.224	0.394	0.568
<b>Pull 8</b>	0.184	0.308	0.596
<b>Pull 9</b>	0.173	0.360	0.481
<b>Pull 10</b>	0.199	0.367	0.543

**Table 2: Voltage Data, By Pull**

<b>Total Area</b>	0.181
<b>Time (s)</b>	0.354
<b>Average Voltage (V)</b>	0.515
<b>Average Current (A)</b>	5.15E-05
<b>Average Current (mA)</b>	0.052
<b>Electrical Charge (mA*s)</b>	0.018

**Table 3: Averages across tests**

This calculation uses a Riemann sum to approximate the average voltage in the circuit during the time taken to pull the DMG, which is then used to calculate the average current in the circuit over time. This Riemann sum is an approximation of the area under the curves shown in Figure 8. Thus, given the current and time, power and electric charge are calculated.

$$V_{avg} = \frac{\int_{t_0}^{t_1} V(t)dt}{t_1 - t_0}$$

For each  $\Delta t$  from  $t_0$  to  $t_1$ :

$$\int_{t_0}^{t_1} V(t)dt \approx \Delta t \cdot \frac{1}{2} [V(t_0) + 2V(t_0 + \Delta t) + 2V(t_0 + 2\Delta t) \cdots + 2V(t_1 - \Delta t) + V(t_1)]$$

Using this data, the following equations can be employed to calculate the electric power output for the DMG for each pull.

$$I_{avg} = \frac{V_{avg}}{R}$$

$$C = I_{avg} \cdot \Delta t_{avg}$$

$$P = C \cdot V_{avg}$$

The calculated average voltage for a pull is approximately 0.515 volts. Using this value and the constant resistance of the circuit (10,000 ohms), the calculated average current per pull is 0.0427 milliamps. Using this information, the electric charge produced per pull is calculated by multiplying the average current by the total duration of the pull, 0.354 seconds, and is determined to be 0.0139 milliamp-seconds.

Finally, the electric power produced per pull is calculated by multiplying this electric charge by the average voltage of the electricity produced, and is determined to be 0.00595 milliwatt-seconds per pull.

### Final Design Improvements

Though the Door Motion Generator works properly in its current state, many components of its design can be improved. Firstly, the entire device must be scaled up slightly, with a larger recoil spring to allow for a draw length that is at least the length of pull of the door. A low-RPM DC generator would also improve the DMG's electricity generation efficiency. Though DC motors and generators rely on the same internal "DC machine," some motors act better as generators than others. Specifically, "the magnitude of the back EMF is proportional to the number of turns in the armature winding and the time-rate-of-change of the field flux as seen by the armature winding. If steady-state operation is assumed, the time-rate-of-change of the flux is just the product of the rotor velocity and the flux magnitude." (College of Electrical and Computer Engineering, 2015) Therefore, the following equation can be used to describe the voltage induced by a generator<sup>3</sup>:

$$E = K\omega_m I_f$$

Where:

E = back EMF, volts

K = constant representing armature winding geometry

$\omega_m$  = rotor velocity, Rad/sec

$I_f$  = field current, amperes

Most DC motors are optimized to operate at a specific RPM and range of input voltage. When used as generators, they produce electricity optimally when they are rotated at that specific RPM. Because the rate of rotation of the DMG is much less than that of most DC motors, including the motor used in the current design, it induces a voltage far less than optimal. In order to improve this, future iterations of the design will include a low-RPM, high-voltage DC motor — In order to more closely match the output RPM of the DMG — that will much more efficiently generate electrical energy.

It is also important to consider the use of the electrical energy generated from this device. Currently, there are two apparent possibilities: storing the energy in local batteries, and returning the energy to the grid. The former would limit the scope of the energy's use, and also greatly increase the unit cost, size, and maintenance cost of the DMG. It is therefore evident that returning the energy to the grid is the better option. In order to achieve this, the DMG must either utilize an AC generator or add a DC to AC converter, which presents an electrical engineering challenge. The exact manner in which the generated electricity will be fed back into the grid must also be determined.

Future iterations of the DMG will also incorporate a flywheel design to effectively lengthen the amount of time each pull produces energy. As the door is pulled, the flywheel — which may be the same part as the outer ratchet wheel, or whichever part is attached to the axle — is accelerated to a great angular velocity. In current designs, the mass of that part is small, so it stops rotating almost immediately after the pulling motion stops. With a more massive part, though, the angular momentum induced by the pull will enable it to keep spinning even after the pulling motion finishes, thus generating more electricity.

In order to take better advantage of the energy from each pull, a planetary gearbox could be introduced to the DMG design. The gearbox will increase the number of axle turns per door opening in order to generate a higher RPM, and therefore more electricity. Furthermore, this gearbox will utilize a dual sprag clutch system, and will output the same direction of rotation no matter the input direction. This is beneficial for a number of reasons. Firstly, it will smooth the motion of the door and help to decrease the closing speed, and secondly it will be able to generate energy on the close cycle of the door. When the door is opened and the recoil spring is wound, a significant amount of potential energy is stored in the recoil spring, which, in the current design, is simply

<sup>3</sup> Equations from (College of Electrical and Computer Engineering, 2015)

dissipated through the act of closing the door. In the new design, however, as the door closes, the energy stored in the recoil spring will also be directed through the gearbox and turn the motor, effectively adding an entirely new cycle that was previously unused. To that end, the larger spring that will be added to newer designs of the DMG, in order to better store the energy of the initial pull.

As mentioned previously, the new design will incorporate two sprag clutches. These are significantly better than the current ratcheting centrifugal clutch because they are more compact, far more durable, and the outer and inner components are able to maintain constant contact, as opposed to free-flying arms that take up to a quarter of a rotation to lock into place.

While optimizing the amount of energy that the DMG can produce, it is very important to consider the usability of such a device and its impact on the force necessary to open a door. For this reason, tests must be conducted to determine an optimal amount of pulling force that can generate the most amount of energy possible while still being comfortable for people to exert when using the door. Once the proper amount of force is calculated, the design for DMG will be calibrated accordingly.

The attainment of this optimal amount of force is further complicated by the reality that the many different doors of the world require widely varying amounts of force to open. Since the DMG is designed to be retrofitted to existing doors, it is therefore a necessity that the DMG have the ability to be adjusted on-site to achieve the aforementioned optimal force. Design for such a feature is pending.

With all of these aspects to consider, the possibilities for optimization grow exponentially. It will therefore be necessary to carry out research to determine such details as the correct parameters for the recoil spring draw length and torque, pulley diameter, ratio for the gearbox, motor-generator, overall device size, and economic costs, including manufacturing and unit costs. This process presents an enticing challenge for continued work on the refinement of the Door Motion Generator.

### **Conclusion/Implications**

Though the amount of energy generated with one pull of the Door Motion Generator may seem insubstantial, if applied to heavily trafficked doors it will amount to usable quantities. The current iteration of the DMG requires further design and testing before it can be marketable. At this stage, the main problem to overcome is the admittedly small electricity output that the device provides. Each use only generates an average of 0.3 Volts, and the power output stands around 8 microwatts however this output can be significantly increased through relatively simple changes such as replacing the motor with a more suitable motor-generator. Other future design considerations are enumerated in the Final Design

Improvements section. Even considering the low energy generation of the Door Motion Generator at this phase, the test is considered successful as a proof of concept. Human motion through doors can in fact be harnessed and converted to usable electricity by employing this safe, inexpensive, and non-intrusive device.

### **References**

- Anthony, S. (2012). Will your body be the battery of the future? Retrieved from <http://www.extremetech.com/extreme/135481-will-your-body-be-the-battery-of-the-future>  
College of Electrical and Computer Engineering. (2015). Experiment: DC Machine. Virginia Institute of Technology. <http://doi.org/10.1016/B978-0-08-021714-7.50007-9>
- Kiger, P. J. (2012). How Power Felt Works. Retrieved August 12, 2015, from <http://electronics.howstuffworks.com/gadgets/fitness/power-felt.htm>
- Renewable Energy. (n.d.). Retrieved June 12, 2015, from <http://www.iea.org/aboutus/faqs/renewableenergy/>